

TRM



雙搭載打拔機

Twin Loading Auto Punch M/C



頂瑞機械股份有限公司

TOP RANGE MACHINERY CO., LTD.

高雄縣大寮鄉大發工業區裕民街22號 TEL:886-7-7875588
No.22, Yu Min Street, Ta Fa Industrial Park, FAX:886-7-7879055
Daliao Township, Kaohsiung County, Taiwan(R.O.C.) E-mail:sales@toprange.com.tw

雙搭載打拔機

Twin Loading Auto Punch M/C

規格表 Specification	
設備外型 Overall dimensions	
長度 Length	1500mm
寬度 Width	1300mm
高度 Height	2000mm
工作高度 Working Height	1050mm
電力消耗量 Power consumption	About 20KVA
壓縮空氣需求 Compressed Air	5kg/cm ²
空氣消耗量 Air consumption	6.6L/min(φ 12)
最小壓力 Minimum Pressure	4.5kg/cm ²
總重 Gross Weight	About 1560kg
淨重 Net Weight	About 1560kg
電力需求 Electrical	220v/60hz/3phase 380v/50hz/3phase

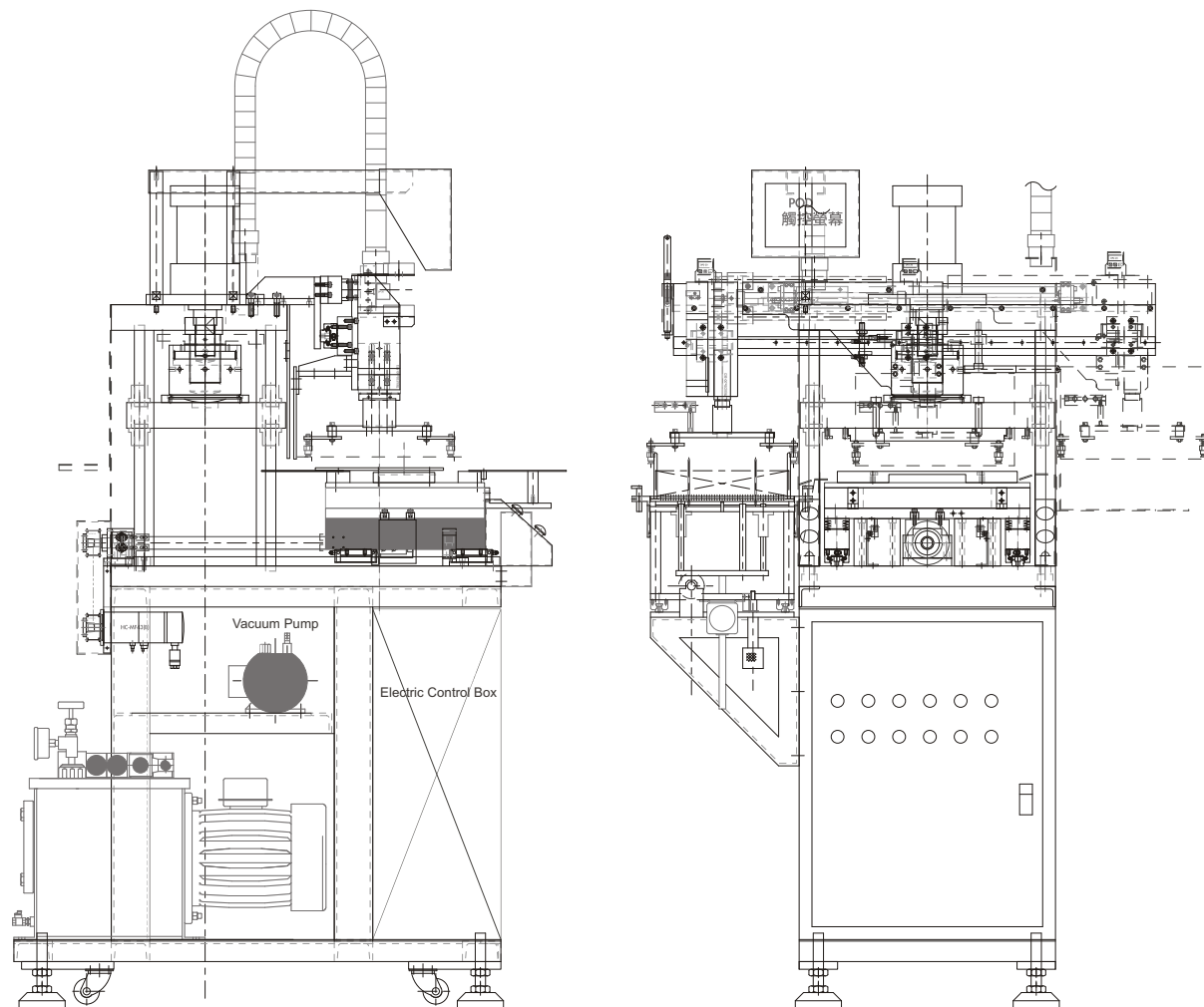

Spec.

- FPC width: 250mm
- Feeding table: 245mm(L) x 280mm(W), pitch 5.0mm
- Tooling setting range: 310mm x Width 150mm、180mm、200mm or 250mm
- Punch depth could adjust ± 10 mm
- Oil pressure: 140kgf/cm² (output 11ton by oil pressure)
- Position precision: ± 0.05 mm

(本型錄內容僅供參考，詳細規格請與本公司聯繫)
(Reference only, for further information please contact us)